

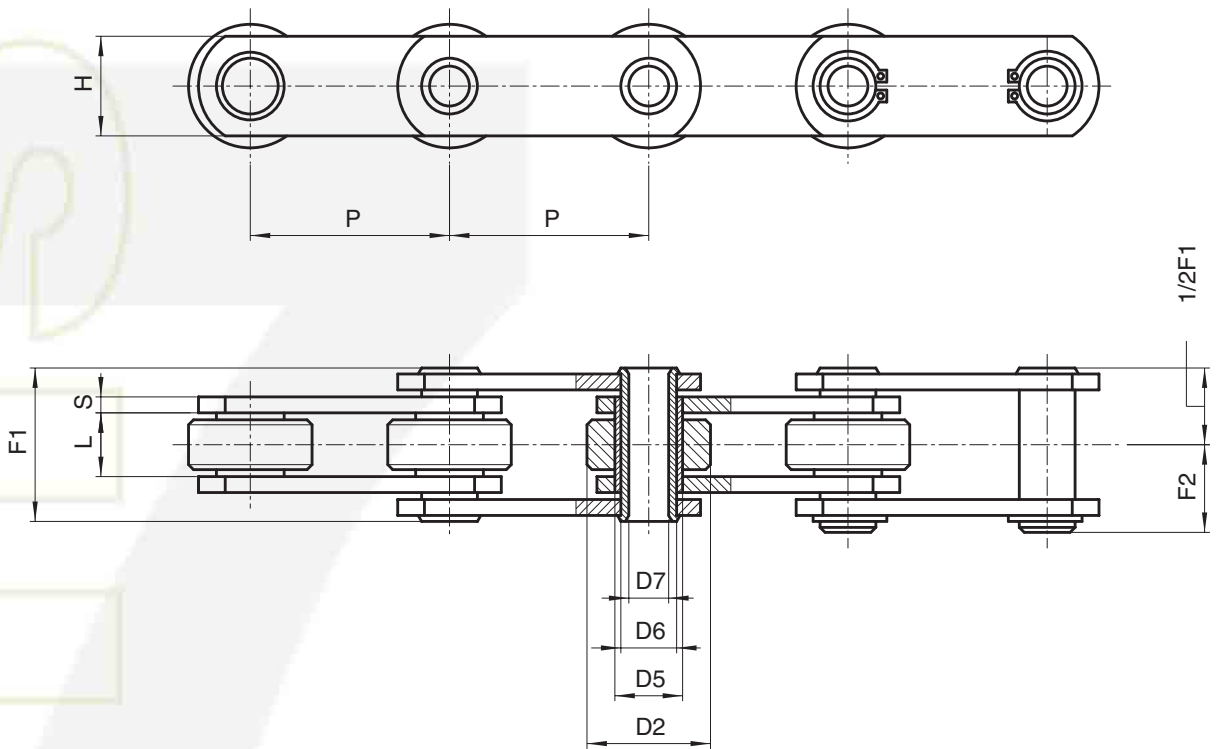

CHAINS FOR SPECIAL APPLICATIONS – SWARF HANDLING



HOLLOW PIN CHAINS

Chain N.	P mm	L mm	D2 mm	D5 mm	D6 mm	D7 mm	H mm	S mm	F1 mm	F2 mm	 Breaking load N	Chain weight kg/m
C2059	31,75	9,53	19,05	10,2	7,02	5,12	15	2	20,1	11,5	19.600	1,2
W2056	38,1	12,7	22,23	11	9	6,2	18	2,5	25,5	13,75	26.500	1,9
3520Z	35	16	20	17	14	10,2	26	2,5	30	16,7	25.000	2,2
W1667	40	9	22	12	9	6,2	18	2,5	23	13	15.500	1,7
W1948	40	13	25	15	12	8,9	22	3	29	16,7	21.000	2,4
400C ♦	50	15	31	17	14	10,2	25	3	31	17,5	35.000	3
W3635	50	15	31	17	14	10,2	25	3	31	17,5	35.000	3
500C	50	15	31	17	14	10,2	25	4	35	19,5	40.000	3,6
500CSS*	50	15	31	17	14	10,5	25	4	36	19,5	35.000	3,6
W4086Z	50	15	40	17	14	10,5	25	4	36	19,5	40.000	3,8
W2795	50	11,5	25	16	13,2	10,5	23	2,5	25	15	16.000	1,8
W2137R	63	15	40	/	16	12,3	28,5	4	35	20	80.000	4,7
W4601	63	21,5	40	/	16	10,5	28,5	4	42	22	50.000	4,7
W5048	63	18	40	17	14	10,2	28	4	38	20,5	50.000	4,1
6540C	65	18	40	17	14	10,2	25	4	38	21	40.000	4,8
701C	75	22	40	23	18	12,2	35	4	42	24	60.000	4,6
W4671R	75	18	40	/	20	15,2	30	4	38,5	21,5	55.000	4,7
703C	100	22	40	23	18	12,2	35	4	42	24	60.000	4,6
704C	125	22	40	23	18	12,2	35	4	42	24	60.000	4,2
W1521/1 ▲	125	30	60/76	25	20	14,5	40	5	56	31	70.000	9
ZC150C1524X	152,4	25,4	66,7	33	26,9	20,1	50	7/5	58	34,5	150.000	9,7

- * stainless steel chain
- ♦ chain with shaped plates
- ▲ chain with flanged rollers



CHAINS FOR SPECIAL APPLICATIONS – SWARF HANDLING

SOLID PIN CHAINS

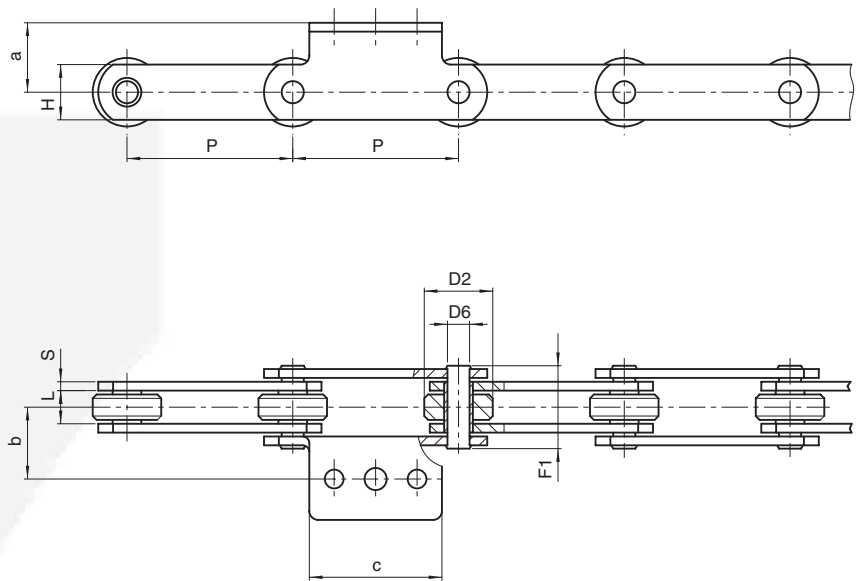

Chain N.	P mm	L mm	D2 mm	D6 mm	H mm	S mm	F1 mm	a mm	b mm	c mm	Breaking load N	Chain weight kg/m
C2052A204	31,75	9,6	19	5,1	15,1	2	20,4	11,1	15,9	25,4	26.500	1,3
4218	42	22	18	5,7	20	4	42,5				32.000	2,9
500	50	15	31	10	25	4	36,6	22	45	45	45.000	3,9
205BA108	50	11,5	25	5,7	18	2,5	25,9	14	33	46	18.000	1,8
703BA310	100	22	40	12	35	4	44	26	38	70	75.000	5

SOLID PIN CHAINS

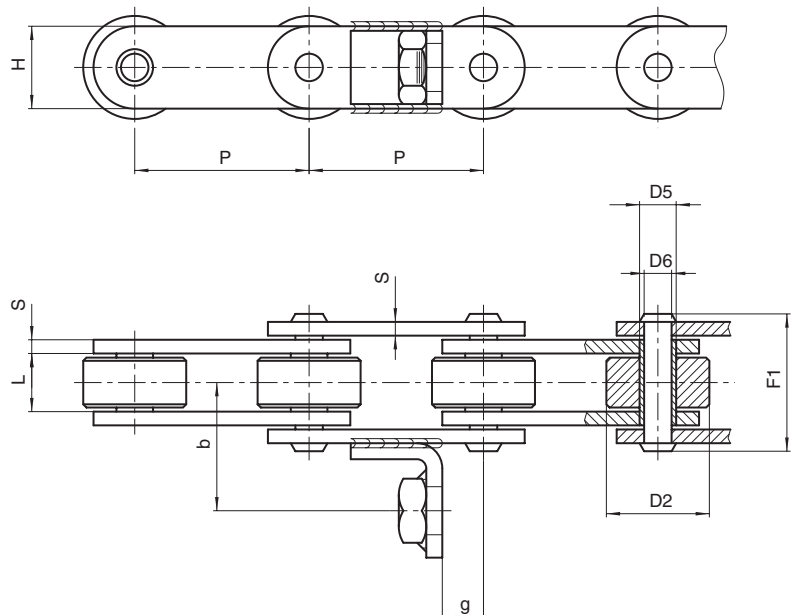

Chain N.	P mm	L mm	D2 mm	D5 mm	D6 mm	H mm	S mm	F1 mm	g mm	b mm	Breaking load N	Chain weight kg/m
W1949AR	38,1	12,7	22,2	8	6	18	3	30	9	28	38.000	3,3
W4584	63	22	40	17	12	30	4	43	16,5	34	66.000	6,1

