

2.10 **Dimensioni**

2.10 **Dimensions**

2.10 **Abmessungen**

	TA...- TF...				
	56B		63B		
R	73.5		75		
F	9		9		
e	45		50		
H h8	65		70		
X h8	65		80		
E h8	65		70		
M	M8		M8		
C f8	70		80		
K	85		100		
L	59		65		
S	71		85		
f	9		9		
m	45		55		
c	73.5		80		
N2	6	8	8	8	8
M2	22.8	28.3	28.3	31.3	33.3
D2 H7	20	25	25	28	30
b	73.5		75		
r	45		50		
B	92		111		
G	90		100		
V	97		117		
C2	100		120		
F2	9		9		
N1	4		4		
M1	13.8		13.8		
D1h6	12		12		
d ₁	M4x10		M4x10		
L1	17.5		17.5		
h	113		120.2		
T	—		—		
	TA.. - TF..				
kg	4.5		6.0		

	TA...- TF...				
	56C		63C		
R	73.5		75		
F	9		9		
e	45		50		
H h8	65		70		
X h8	65		80		
E h8	65		70		
M	M8		M8		
C f8	70		80		
K	85		100		
L	94		100		
S	36		50		
f	9		9		
m	45		55		
c	73.5		80		
N2	6	8	8	8	8
M2	22.8	28.3	28.3	31.3	33.3
D2 H7	20	25	25	28	30
b	73.5		75		
r	45		50		
B	92		111		
G	90		100		
V	97		117		
C2	100		120		
F2	9		9		
N1	4		4		
M1	13.8		13.8		
D1h6	12		12		
d ₁	M4x10		M4x10		
L1	17.5		17.5		
h	146.6		153.7		
T	229		241.2		
	TA.. - TF..				
kg	5.0		6.5		

IEC..B5	TF...																			
	56B					56C					63B					63C				
	56	63	71	80	90	56	63	71	80	90	56	63	71	80	90	56	63	71	80	90
Y	120	140	160	200	200	120	140	160	200	200	120	140	160	200	200	120	140	160	200	200
P	153	156	163	183	183	187	190	197	217	217	160	163	170	190	190	194	197	201	221	221
Q	218	221	228	248	248	252	255	262	282	282	230	233	240	260	260	264	267	271	291	291
kg	4.5	4.5	4.5	4.5	4.5	5.0	5.0	5.0	5.0	5.0	6.0	6.0	6.0	6.0	6.0	6.5	6.5	6.5	6.5	6.5

IEC..B14	TF...																			
	56B					56C					63B					63C				
	56	63	71	80	90	56	63	71	80	90	56	63	71	80	90	56	63	71	80	90
Y	—	—	105	120	140	—	—	105	120	140	—	—	105	120	140	—	—	105	120	140
P	—	—	163	183	183	—	—	197	217	217	—	—	170	190	190	—	—	204	224	224
Q	—	—	228	248	248	—	—	262	282	282	—	—	240	260	260	—	—	274	294	294
kg	—	—	4.5	4.5	4.5	—	—	5.0	5.0	5.0	—	—	6.0	6.0	6.0	—	—	6.5	6.5	6.5

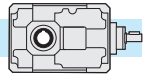

T..56B - T..56C - T..63B - T..63C

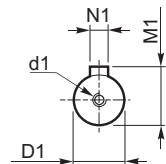
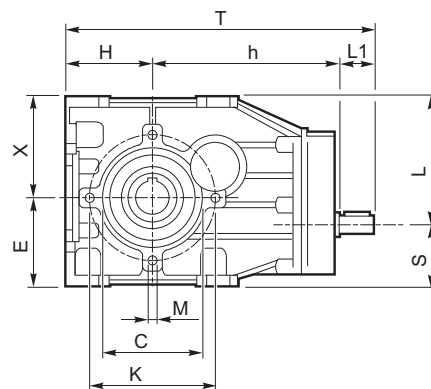
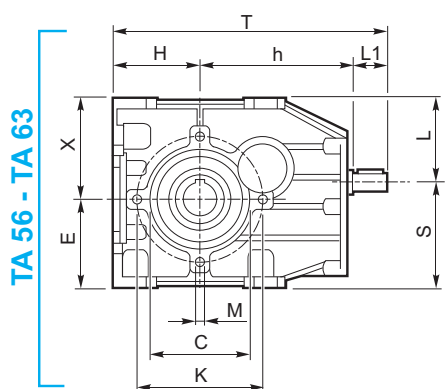
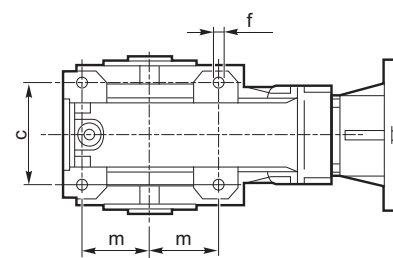
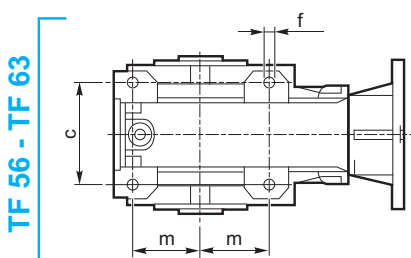
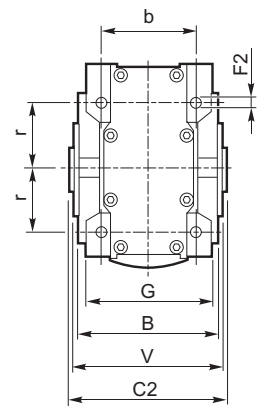
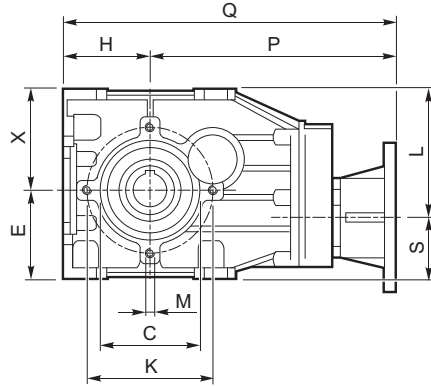
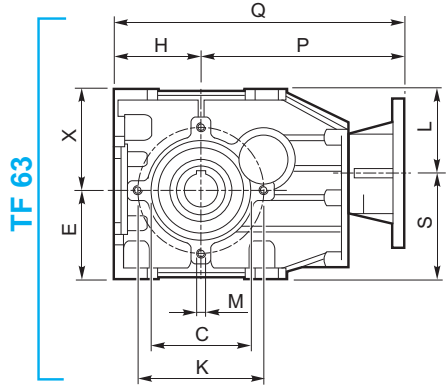
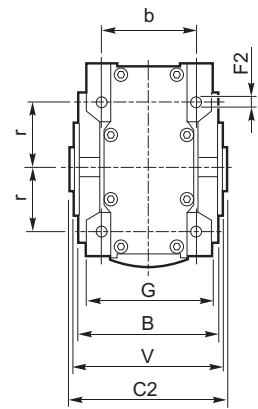
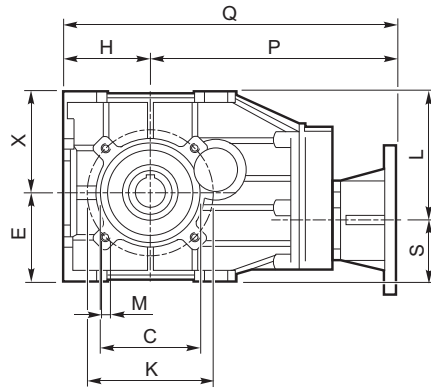
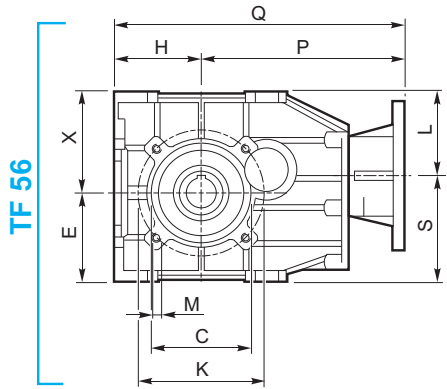
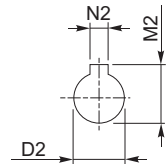
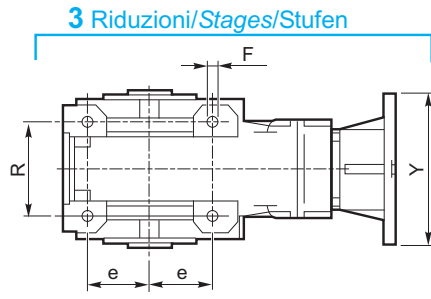
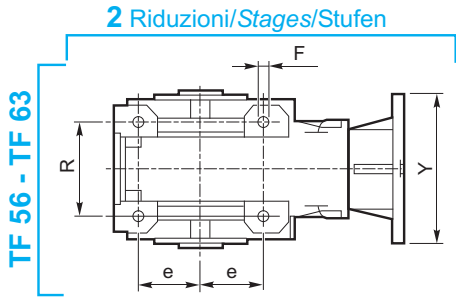

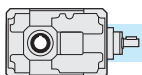

2.10 Dimensioni

2.10 Dimensions

2.10 Abmessungen

TA... - TC... - TF...																
	71B			90B			112B			140B		180B		200B		225B
A	142			180			224			280		360		400		450
a	102			134			166			209		272.5		305		344
a1	—			—			—			—		—		—		—
B	112			127			150			175		215		255		290
b	90			104			125			145		180		210		240
C2	115			130			155			180		220		260		300
D1 h6	14			19			24			28		38		38		48
D2 H7	24	28	30	32	30	35	42	40	45	55	50	70	60	90	80	100
E	206			262			326			407		522.5		585		654
e	38			52			64			82		110		120		140
F	9			11			13			15		17		19		21
f	M8x13			M10x16			M12x19			M14x22		M16x25		M18x35		M18x30
G	122			155			194			244		320		350		400
g	61			77.5			97			122		160		175		200
H	71			90			112			140		180		200		225
h	174			212			262			317		400		422.5		500
l	110			130			160			190		237.5		237.5		296
i	125			159.5			199			249		322.5		360		404
L1	30			40			50			60		80		80		110
O	64			82			102			127		162.5		185		204
T	275			342			424			517		660		702.5		835
t	211			260			322			390		497.5		517.5		631
Z	9			11			13			15		17		22		25

TA..														
kg	12.5		20		34		58		116		165		232	

TC... - TF...														
kg	15.5		25		44		75		136		185		270	

TC...												
	71B				90B				112B			
IEC	63 B5	71 B5	80/90 B5	80 B14	71 B5	80/90 B5	*90 B14	100/112 B5	80/90 B5	100/112 B5	132 B5	
Y	140	160	200	120	160	200	□120 / R73	250	200	250	300	
P	177	184	204	204	220	240	240	250	286	296	318	
p	113	120	140	140	138	158	158	168	184	194	216	
Q	248	255	275	275	310	330	330	340	398	408	430	
q	184	191	211	211	228	248	248	258	296	306	328	

	140B				180B				200B					
IEC	80/90 B5	100/112 B5	132 B5	160/180 B5	100/112 B5		132 B5	160/180 B5	200 B5	100/112 B5		132 B5	160/180 B5	200 B5
Y	200	250	300	350	250		300	350	400	250		300	350	400
P	331	341	363	393	413(i=10-40) / 423(i=50-80)		463(i=10-40) / 473(i=50-80)		435(i=8-40) / 445(i=50-63)		485(i=8-40) / 495(i=50-63)			
p	204	214	236	266	250(i=10-40) / 260(i=50-80)		300(i=10-40) / 310(i=50-80)		250(i=8-40) / 260(i=50-63)		300(i=8-40) / 310(i=50-63)			
Q	471	481	503	533	593(i=10-40) / 603(i=50-80)		643(i=10-40) / 653(i=50-80)		640(i=8-40) / 650(i=50-63)		690(i=8-40) / 700(i=50-63)			
q	344	354	376	406	430(i=10-40) / 440(i=50-80)		480(i=10-40) / 490(i=50-80)		450(i=8-40) / 460(i=50-63)		500(i=8-40) / 510(i=50-63)			

* Flange quadrata / Square flanges / Viereckige Flansche

TF...													
	71B			90B			112B			140B			
IEC	63 B5	71 B5	80/90 B5	71 B5	80/90 B5	100/112 B5	80/90 B5	100/112 B5	132 B5	80/90 B5	100/112 B5	132 B5	160/180 B5
Y	140	160	200	160	200	250	200	250	300	200	250	300	350
P	231	238	259	286	307	317	367	377	398	432	442	463	493
p	167	174	195	204	225	235	265	275	296	305	315	336	366
Q	302	309	330	376	397	407	479	489	510	572	582	603	633
q	238	245	266	294	315	325	377	387	408	445	455	476	506

	180B				200B				225B			
IEC	100/112 B5	132 B5	160/180 B5	200 B5	100/112 B5	132 B5	160/180 B5	200 B5	132 B5	160/180 B5	200 B5	225 B5
Y	250	300	350	400	250	300	350	400	300	350	400	450
P	546	566	596	596	568.5	588.5	618.5	620.5	698	728	728	760
p	393.5	403	433	433	383.5	403.5	433.5	435.5	494	524	524	556
Q	736	746	776	776	768.5	788.5	818.5	820.5	923	953	953	985
q	573.5	583	613	613	583.5	603.5	633.5	635.5	774	749	749	781

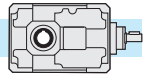

T..71B - T..225B

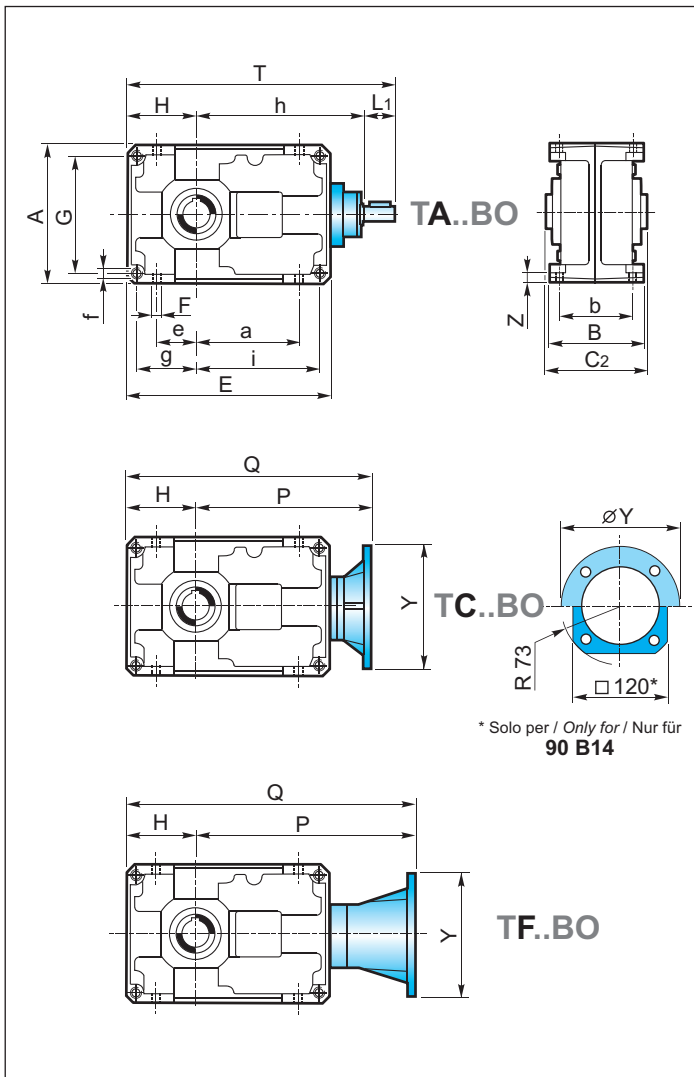

* Solo per / Only for / Nur für
90 B14

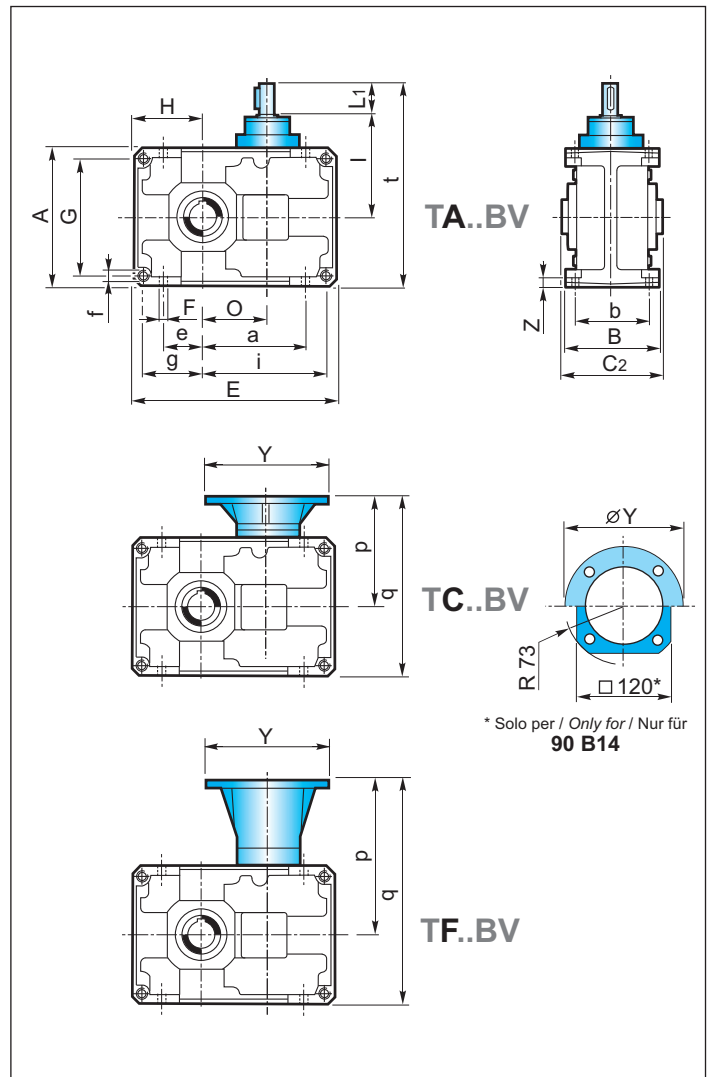

* Solo per / Only for / Nur für
90 B14

Albero uscita cavo
Hollow output shaft
Abtriebshohlwelle

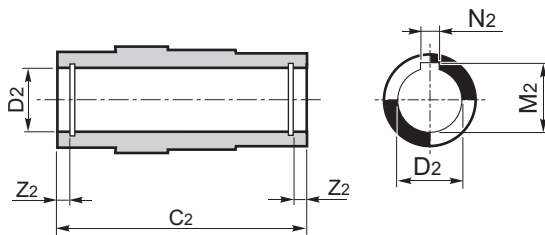

Albero entrata
Input shaft
Antriebswelle

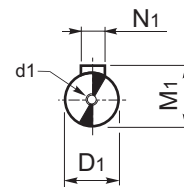

	TA... - TC... - TF...															
	71B			90B			112B			140B		180B		200B		225B
D1 h6	14			19			24			28		38		38		48
d1	M4x15			M8x22			M8x22			M8x22		M10x28		M10x28		M12x34
M1	16			21.5			27			31		41		41		51.5
N1	5			6			8			8		10		10		14
C2	115			130			155			180		220		260		300
D2 H7	24	28	30	32	30	35	42	40	45	55	50	70	60	90	80	100
M2	27.3	31.3	33.3	35.3	33.3	38.3	45.3	43.3	48.8	59.3	53.8	74.9	64.4	95.4	85.4	106.4
N2	8	8	8	10	8	10	12	12	14	16	14	20	18	25	22	28
Z2	—			8.7	8.7	8.4	11	11	11	11.9	11.9	15.4	15.9	18.9	18.9	20

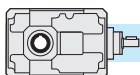

2.10 Dimensioni

2.10 Dimensions

2.10 Abmessungen

TA... - TC... - TF...													
	80C			100C			125C		160C		180C		200C
A	160			200			250		320		360		400
a	82			102			127		162.5		185		204
a1	106			134			169		217		207		277.5
B	127			150			175		215		255		290
b	104			125			145		180		210		240
C2	130			155			180		220		260		300
D1 h6	14			19			24		28		28		38
D2 H7	32	30	35	42	40	45	55	50	70	60	90	80	100
E	306			384			479		609.5		652		766.5
e	42			52			67		90		100		115
F	11			13			15		17		19		21
f	M10x16			M12x19			M14x22		M16x25		M18x35		M18x30
G	135			170			214		280		310		350
g	67.5			85			107		140		155		175
H	80			100			125		160		180		200
h	256			314			389		479.5		502		604
l	110			130			160		190		190		237.5
i	213.5			269			336		429.5		447		541.5
L1	30			40			50		60		60		80
O	146			184			229		289.5		312		366.5
T	366			454			564		699.5		742		884
t	220			270			335		410		430		517.5
Z	11			13			16		17		22		25

TA..									
kg	19		36		66		120	170	260

TC... - TF...									
kg	22		41		76		137	190	295

TC...												
	80C				100C				125C			
IEC	63 B5	71 B5	80/90 B5	80 B14	71 B5	80/90 B5	*90 B14	100/112 B5	80/90 B5	100/112 B5	132 B5	
Y	140	160	200	120	160	200	□120 / R 73	250	200	250	300	
P	259	266	286	286	322	342	342	352	413	423	445	
p	113	120	140	140	138	158	158	168	184	194	216	
Q	339	346	366	366	422	442	442	452	538	548	570	
q	193	200	220	220	238	258	258	268	309	319	341	

	160C				180C				200C			
IEC	80/90B5	100/112 B5	132 B5	160/180 B5	80/90 B5	100/112 B5	132 B5	160/180 B5	100/112 B5	132 B5	160/180 B5	200 B5
Y	200	250	300	350	200	250	300	350	250	300	350	400
P	493	503	525	555	516	526	548	578	617(i=40-160) / 627(i=200-315)	667(i=40-160) / 677(i=200-315)		
p	204	214	236	266	204	214	236	266	250(i=40-160) / 260 (i=200-315)	300(i=40-160) / 310 (i=200-315)		
Q	653	663	686	715	696	706	728	758	617(i=40-160) / 627(i=200-315)	867(i=40-160) / 877(i=200-315)		
q	364	374	396	426	384	394	416	446	450(i=40-160) / 460(i=200-315)	500(i=40-160) / 510(i=200-315)		

* Flange quadrata / Square flanges / Viereckige Flansche

TF...												
	80C				100C				125C			
IEC	63 B5	71 B5	80/90 B5	71 B5	80/90 B5	100/112 B5	80/90 B5	100/112 B5	132 B5	160/180 B5	132 B5	
Y	140	160	200	160	200	250	200	250	200	250	300	
P	313	320	341	388	409	419	494	504	525	525	525	
p	167	174	195	204	225	235	265	275	296	296	296	
Q	393	400	421	488	509	519	619	629	650	650	650	
q	247	254	275	304	325	335	390	400	421	421	421	

	160C				180C				200C			
IEC	80/90 B5	100/112 B5	132 B5	160/180 B5	80/90 B5	100/112 B5	132 B5	160/180 B5	132 B5	160/180 B5	200 B5	
Y	200	250	300	350	200	250	300	350	300	350	400	
P	594	604	625	655	617	627	648	678	770	800	802	
p	305	315	336	366	305	315	336	366	404	434	436	
Q	754	764	785	815	797	807	828	858	970	1000	1002	
q	465	475	496	526	485	495	516	546	604	634	636	

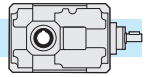

T..80C - T..200C

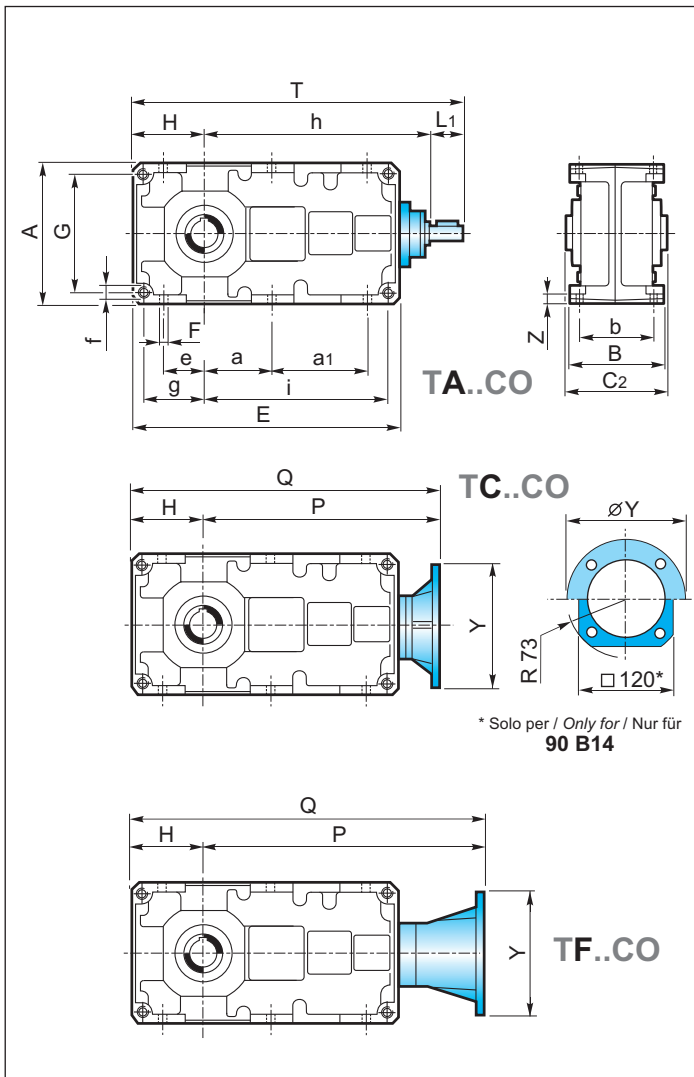

* Solo per / Only for / Nur für
90 B14

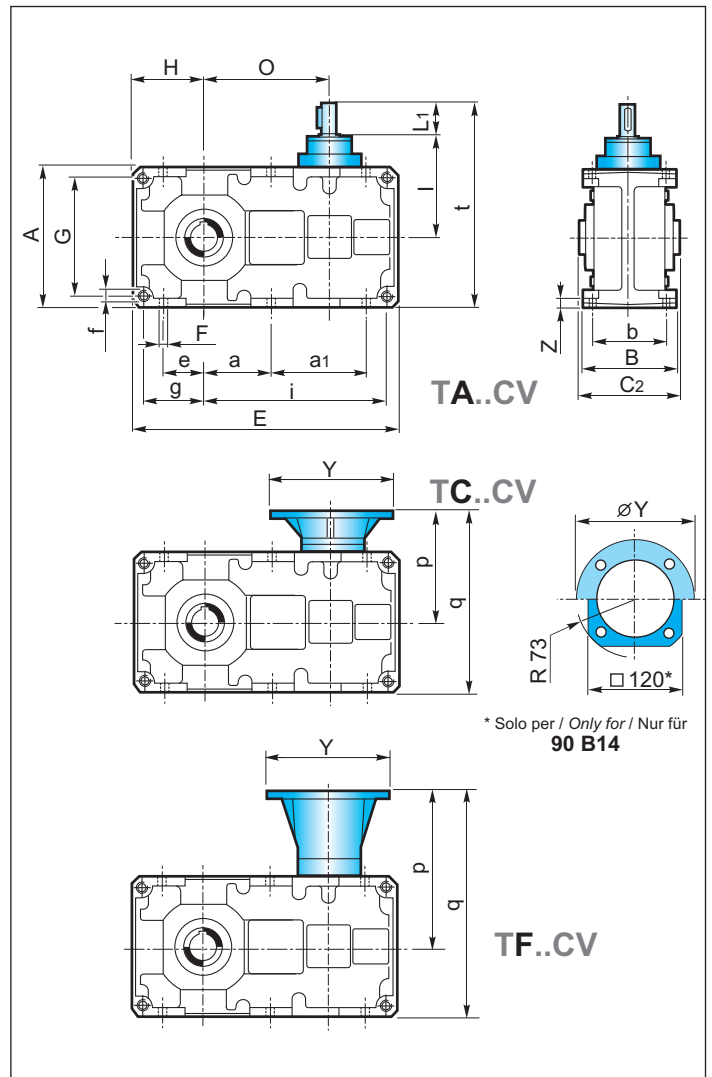

* Solo per / Only for / Nur für
90 B14

Albero uscita cavo
Hollow output shaft
Abtriebshohlwelle

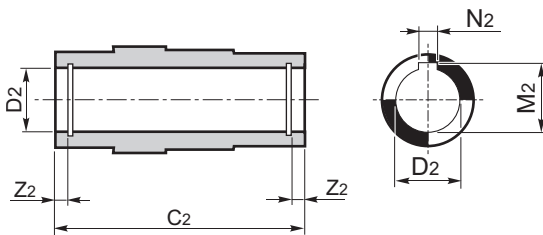

Albero entrata
Input shaft
Antriebswelle

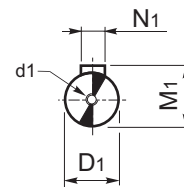

	TA... - TC... - TF...												
	80C			100C			125C		160C		180C		200C
D1 h6	14			19			24		28		28		38
d1	M4x15			M8x22			M8x22		M8x22		M8x22		M10x28
M1	16			21.5			27		31		31		41
N1	5			6			8		8		8		10
C2	130			155			180		220		260		300
D2 H7	32	30	35	42	40	45	55	50	70	60	90	80	100
M2	35.3	33.3	38.3	45.3	43.3	48.8	59.3	53.8	74.9	64.4	95.4	85.4	106.4
N2	10	8	10	12	12	14	16	14	20	18	25	22	28
Z2	8.7	8.7	8.4	11	11	11	11.9	11.9	15.4	15.9	18.9	18.9	20